

ValuPoint®  
Programmable I/O

CONTROL SOLUTIONS, INC.  
MINNESOTA

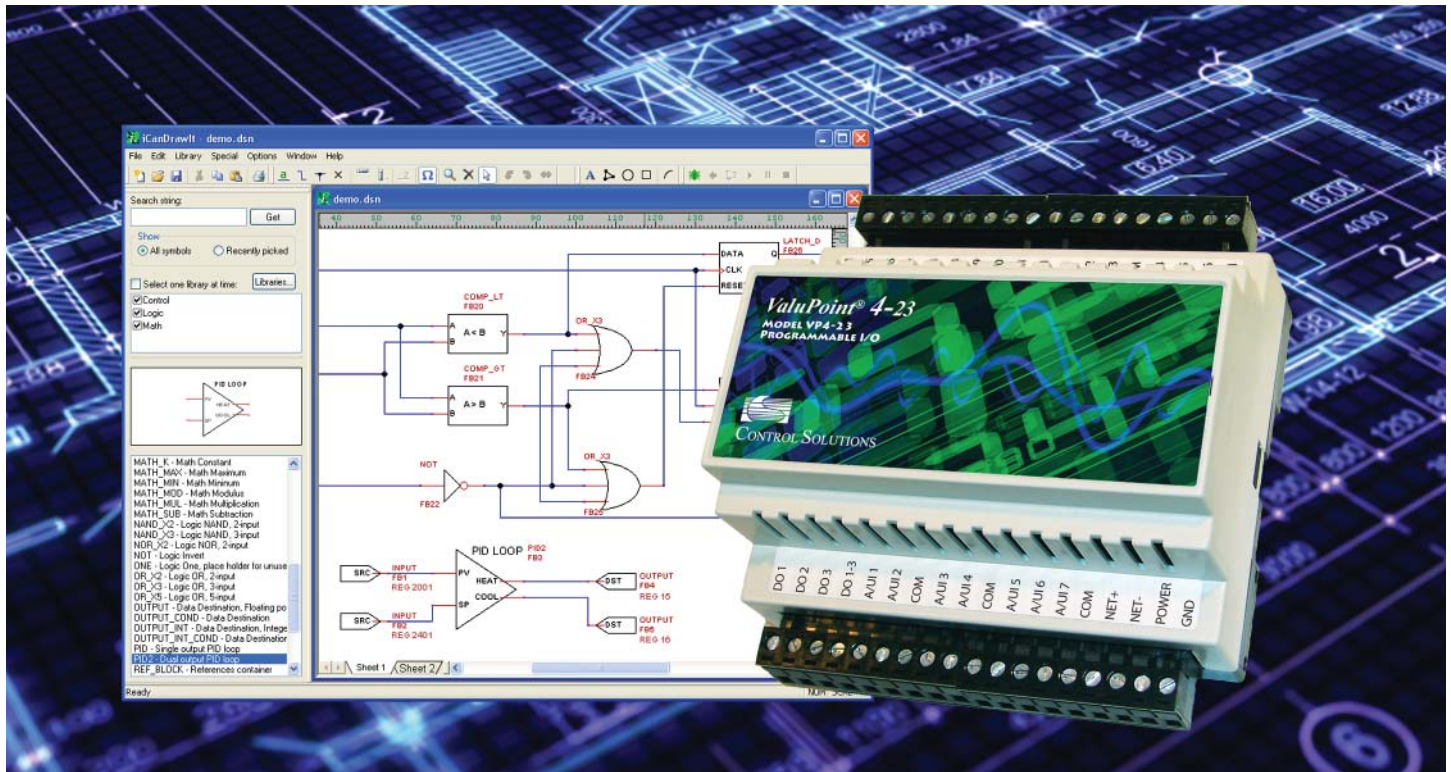

## ValuPoint® Model VP4-2310

Control Solutions' Model VP4-2310 ValuPoint® Programmable I/O for Modbus RTU operates as a master or slave for I/O expansion, or as a controller with soft PLC capability. The 4th generation ValuPoint® platform features 14 universal context sensitive inputs. When configured as an analog input, the continuously self-calibrating sigma-delta converter produces 15-bit resolution with high noise immunity. When configured as a discrete input, the converter switches to 10-bit resolution at 1,000 samples per second for fast response. ValuPoint 4-23 also includes 3 analog outputs, 6 Form A relay outputs, and pulse counting capability on all inputs.

### Software Features of Model VP4-2310

- Modbus RTU Master or Slave
- Freely programmable - *i.CanDrawIt*® graphical programming
- Includes uncommitted registers for soft PLC use
- All registers accessible as 16-bit or 32-bit including IEEE754
- Modbus Master can query registers in other Modbus devices
- Local registers mirror data mapped from other devices
- Registers accessible as coils, discretes, holding registers

### Hardware Features of Model VP4-2310

- 14 Analog/universal inputs, software selectable types
  - 0-10VDC, thermistor, discrete, dry contact, pulse
  - 0.1% reference, up to 16-bit resolution
  - Continuously self-calibrating sigma-delta converter
  - Non-volatile totalizing count inputs
    - (to 10Hz on all channels, to 1kHz on 2 channels)
    - 10-bit fast scan mode
- 3 Analog outputs
  - 4-20mA (0-20mA), 8-bit resolution, 500 ohm load max.
- 6 Discrete outputs
  - Form A relay
  - 2A @ 120VAC
  - 2A @ 30VDC
- Battery backed real time clock/calendar
- Modbus RTU at 4800 to 38400 baud
- Hardened RS-485 port
- 128KB non-volatile EEPROM configuration file capacity
- 64K Flash for User Program
- ARM 32-bit processor, 512K Flash, 56K RAM
- Powered by 18-30VDC or 24VAC 50/60 Hz
  - 0.3A @ 24VDC
- DIN rail mounting, 100mm H x 105mm W x 60mm D
- -40C to +70C, 5%-95% RH non-condensing
- Certifications: FCC, CE, UL 916 Listed

**ValuPoint®**  
Programmable I/O

**CONTROL SOLUTIONS, INC.**  
MINNESOTA

## ValuPoint® - An Outstanding Value

The ValuPoint® series of controllers is designed to be a building block in a distributed control system. The VP4-2310 can be used as Modbus slave for system expansion, or as Modbus master for stand-alone applications. When configured as Master, the VP4-2310 can query other Modbus devices, and use local registers to mirror mapped registers in remote devices.

All of the ValuPoint features available to local objects are also available to the remote mapped objects. This means the remote objects can be incorporated into the local i.CanDrawIt® program.

The VP4-2310 has a total of 320 data objects, of which the first several are assigned to physical I/O points. The remaining objects may be used as local storage for the soft PLC program, or may be used to mirror remote registers in other Modbus slaves. Each data object may be accessed as 16-bit or 32-bit integer, or floating point. Discrete points may be read as holding registers, coils, or discrete inputs. Analog points may be read as holding or input registers.

ValuPoint® support software, available for download at no cost, includes the VP4-2310 configuration tool, i.CanDrawIt graphical programming tool, and the pliWrite line programming tool. Both programming tools support both simulated execution and live debug. The tools connect via any serial COM port with an RS485 adapter.

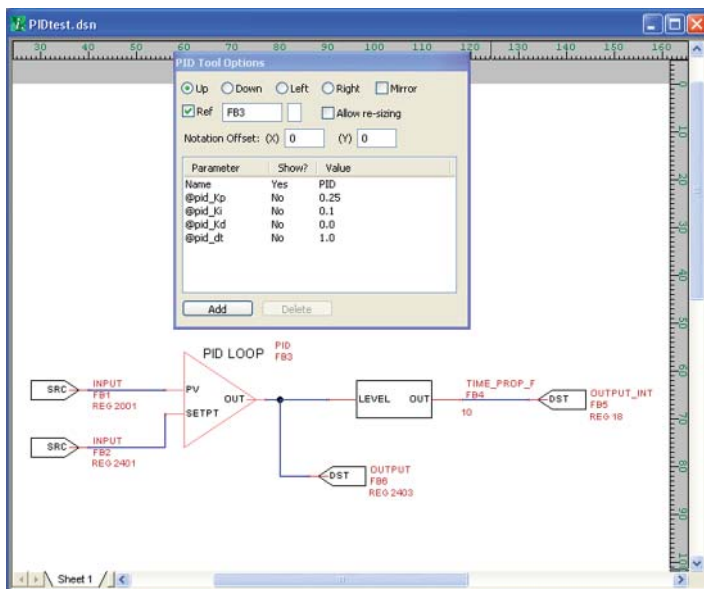

## i.CanDrawIt®

**i.CanDrawIt®** works just like an electrical schematic CAD program, except you draw control programs that look like circuits. The resulting software will function like the circuit you draw. i.CanDrawIt® includes visual program simulation as well as visual live debugging where supported by the target device. Set breakpoints or step through the program one visual function block at a time. Update variables and I/O objects in simulation or live.

- Draw control programs
- Electrical CAD look and feel
- Ladder style, free form logic, or hybrid
- Compile code from drawings
- Simulate functions block by block
- Run to break point
- Run until paused
- Inspect or change variables
- Inspect or change registers (object's value property)
- Draw new function blocks
- Library source code included

i.CanDrawIt® is included at no additional cost with every ValuPoint® controller from Control Solutions Minnesota.

- No supporting software to buy
- No license fees, no run-time licenses
- Includes no-fee online support
- No time limits, no functional limits or disabled features

Visit our web site for

- Full details
- On-line Ordering

[www.csimn.com](http://www.csimn.com)



**CONTROL SOLUTIONS, INC.**

380 OAK GROVE PKWY, SUITE 100 • PO BOX 10789

ST. PAUL, MN 55110-0789

VOICE (651) 426-4410 • FAX (651) 426-4418

TOLL FREE 1-800-872-8613

© 2013 Control Solutions, Inc. ValuPoint® is a registered trademark of Control Solutions, Inc. Modbus® is a registered trademark of Modbus Organization, Inc.