

ValuPoint®
PROGRAMMABLE I/O

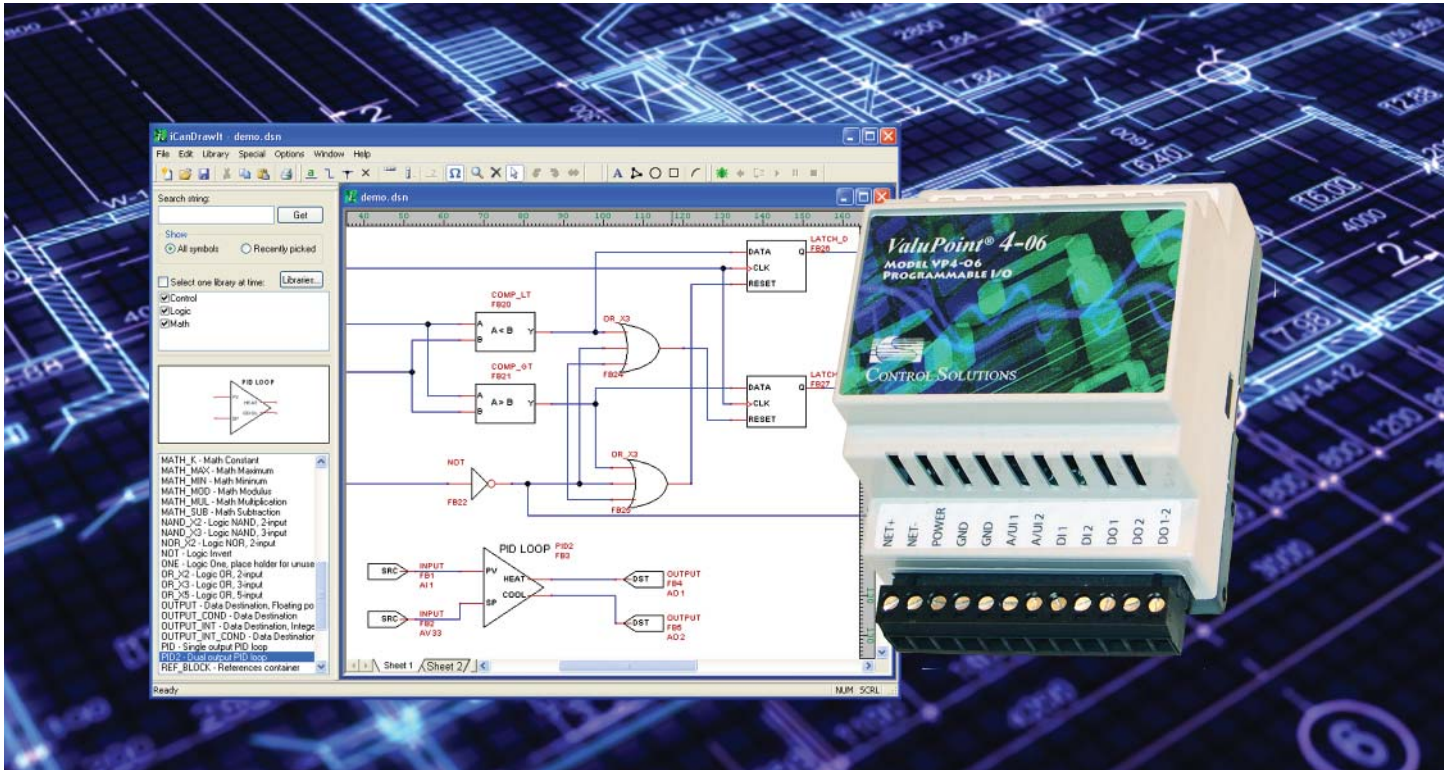

CONTROL SOLUTIONS, INC.
MINNESOTA



ValuPoint® Model VP4-0630

Control Solutions' Model VP4-0630 ValuPoint® Programmable I/O for BACnet MS/TP is a BACnet Application Specific Controller (B-ASC) that includes programmable control. The VP4-0630 is a scaled down, low cost version of the VP4-2330 featuring 2 universal inputs that may be configured as analog or discrete, 2 dedicated discrete inputs, and 2 Form A relay outputs. The ValuPoint VP4-0630 is useful as slave I/O or as a very small soft PLC.

Software Features of Model VP4-0630

- Implements B-ASC BACnet Standard Profile
- Freely programmable - *i.CanDrawIt®* graphical programming
- COV Subscription support
- BACnet client for interface to other slave devices
- I/O points and undedicated BACnet objects
 - Input objects: AI, BI, MSI
 - Commandable output objects: AO, BO, MSO
 - Writeable value objects: AV, BV, MSV
- Configurable object allocation, up to 200 objects

Hardware Features of Model VP4-0630

- 2 Analog/universal inputs, software selectable types
 - 0-10VDC, discrete, pulse count
 - 10-bit A/D resolution
 - Non-volatile totalizing count inputs
- 2 Discrete Inputs
 - Dry contact closure to ground
 - Pulse count (10Hz) capability
 - Non-volatile totalizing count inputs
- 2 Discrete outputs
 - Form A relay
 - 2A @ 120VAC
 - 2A @ 30VDC
- BACnet MS/TP at 9600 to 76800 baud
- Hardened RS-485 port
- 128KB non-volatile EEPROM configuration file capacity
- 64K Flash for User Program
- ARM 32-bit processor, 512K Flash, 56K RAM
- Powered by 18-30VDC or 24VAC 50/60 Hz
 - 0.2A @ 24VDC
- DIN rail mounting, 100mm H x 70mm W x 60mm D
- -40C to +70C, 5%-95% RH non-condensing
- Certifications: FCC, CE
- Listed to UL 916 and (Canadian) C22.2 No. 205-M1983

ValuPoint®
PROGRAMMABLE I/O



CONTROL SOLUTIONS, INC.
MINNESOTA

ValuPoint® - An Outstanding Value

The ValuPoint® series of controllers is designed to be a building block in a distributed control system where controllers communicate peer to peer via BACnet MS/TP. Each ValuPoint controller can access BACnet objects in other BACnet devices, both ValuPoint controllers and other manufacturer's devices. Remote objects are mapped to local objects that mirror the value of the remote object. Access to the remote objects is via periodic polling. Other devices can subscribe to COV's in the ValuPoint controller.

All of the ValuPoint features available to local objects are also available to the remote mapped objects. This means the remote objects can be incorporated into the local i.CanDrawIt® program.

The user has the ability to assign object allocation as part of setup of the controller. Resources are allocated from a common pool, and the user has the ability to decrease the number of one type of object in order to increase the number of another type. Total object count will range from approximately 100 commandable objects (with full priority array) to 200 read/write objects. Object types include analog, binary, and multi-state variations of input, commandable output, and writable value.

ValuPoint® support software, available for download at no cost, includes the VP4-0630 configuration tool, i.CanDrawIt graphical programming tool, and the pliWrite line programming tool. Both programming tools support both simulated execution and live debug. The tools connect via a BACnet IP to MS/TP router, or via Control Solutions' MTX002 USB to MS/TP adapter.

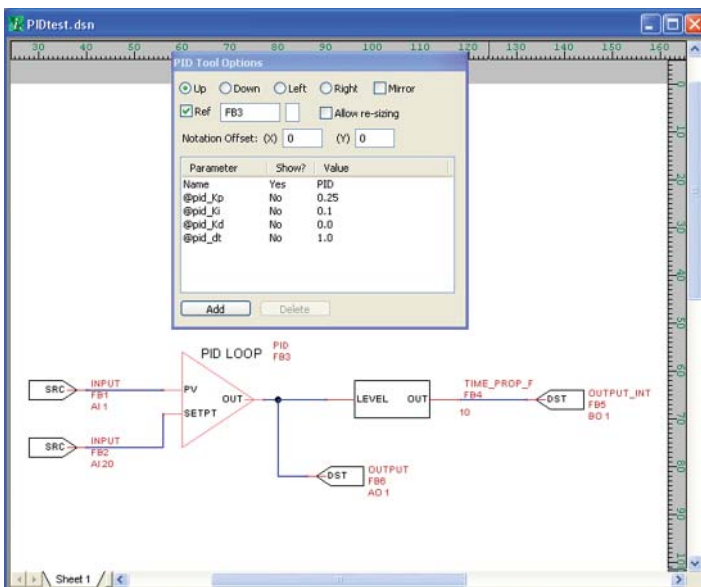

i.CanDrawIt®

i.CanDrawIt® works just like an electrical schematic CAD program, except you draw control programs that look like circuits. The resulting software will function like the circuit you draw. i.CanDrawIt® includes visual program simulation as well as visual live debugging where supported by the target device. Set breakpoints or step through the program one visual function block at a time. Update variables and I/O objects in simulation or live.

- Draw control programs
- Electrical CAD look and feel
- Ladder style, free form logic, or hybrid
- Compile code from drawings
- Simulate functions block by block
- Run to break point
- Run until paused
- Inspect or change variables
- Inspect or change registers (object's value property)
- Draw new function blocks
- Library source code included

i.CanDrawIt® is included at no additional cost with every ValuPoint® controller from Control Solutions Minnesota.

- No supporting software to buy
- No license fees, no run-time licenses
- Includes no-fee online support
- No time limits, no functional limits or disabled features

Visit our web site for

- Full details
- On-line Ordering

www.csimn.com



CONTROL SOLUTIONS, INC.

380 OAK GROVE PKWY, SUITE 100 • PO BOX 10789

ST. PAUL, MN 55110-0789

VOICE (651) 426-4410 • FAX (651) 426-4418

TOLL FREE 1-800-872-8613

© 2016 Control Solutions, Inc. ValuPoint® is a registered trademark of Control Solutions, Inc. BACnet® is a registered trademark of American Society of Heating, Refrigerating and Air-Conditioning Engineers, Inc.