

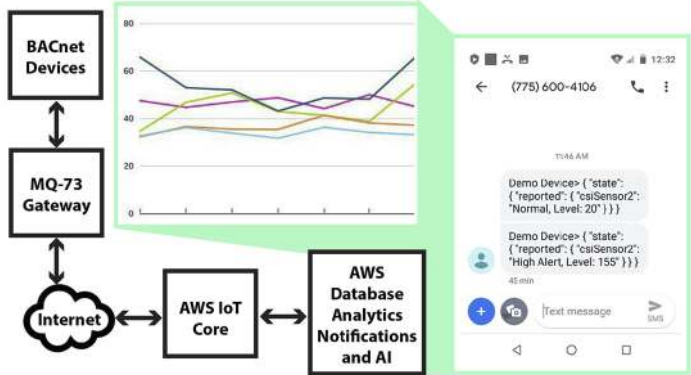

Control Solutions' Babel Buster[®] MQ-73 IoT Gateway turns any BACnet device into a Thing on the Internet of Things. The MQ-73 will poll one or more BACnet devices, collecting data from the list of objects you provide. Based on rules you create, the MQ-73 will decide if and when to publish that data to the MQTT broker (server). You can also configure the MQ-73 to subscribe to data coming from the MQTT broker, which you can then write out to BACnet devices to manage setpoints and the like.

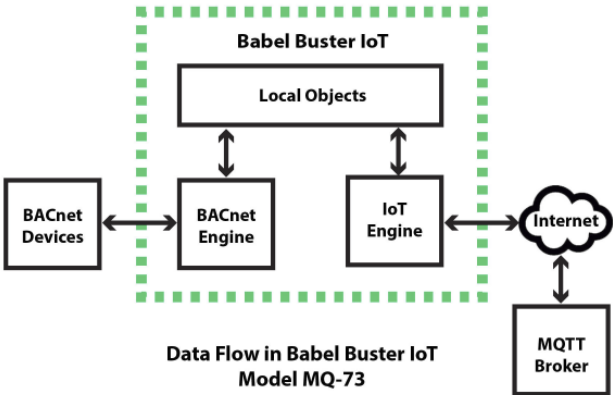

One of the many things you can do with data that has been published to the AWS server by the Babel Buster MQ-73 is analyze and visualize the data, and generate text messages automatically sent to your smart phone. The graph and message illustrated above represent data published by an MQ-73, and the steps taken to get this graph or notification are outlined in the user guide.



The data flow in the MQ-73 is illustrated above. Data is collected from BACnet devices by the BACnet engine which stores that data in local objects. The BACnet data is automatically updated on a continual basis. Meanwhile, the IoT engine is looking at its set of publish and subscribe rules to decide when to publish data from the local objects to the AWS server. These rules are also created by the user and data will be published according to the criteria set up by the user.

The MQTT “publish” action, in controls terms, is most closely associated with sensors. Your hardware has collected sensor data, and you want to send that sensor data to a server or to other control devices. To send that data, you “publish” it.

The MQTT “subscribe” action, in controls terms, is most closely associated with actuators. The “subscribe” action would also be associated with control setpoints. You can never force data into a device via MQTT. The device, in our case the MQ-73, must subscribe to the source of data effectively asking to be informed of changes. Once you have subscribed to an MQTT source of data, then when received, you can use that data to control actuators or update setpoints.

The MQ-73 supports the open source industry standard Mosquitto MQTT broker. The MQ-73 includes additional features to support Amazon’s AWS IoT Core as well as ThingsBoard.



The MQ-73 also supports interactive dashboards using ThingsBoard. The MQ-73 includes features specific to ThingsBoard that allow MQTT interaction with graphic widgets on the dashboard. BACnet data published by the MQ-73 can show up as real-time gauge indications or charts. Input from the dashboard such as knob adjustments or switch changes will be immediately reported to the MQ-73 and those changes are immediately accessible as BACnet data.

The MQ-73 is also a BACnet router, slave proxy, and client/server gateway that allows remapping objects from multiple slaves into one master. You can use the MQ-73 as just a router, just a slave proxy, just a client/server, or all three at the same time. The MQ-73 also includes BBMD support. The MQ-73 includes all of the BACnet functionality of Control Solutions’ BB3-7301.

The MQ-73 as a BACnet Router will route IP to MS/TP and vice versa via its local ports, and supports full router capability for multi-hop inter-networks including via NAT WAN routers. Routing is simple to set up. Routing can be used without any other gateway features enabled.

The MQ-73 as a BACnet Client/Server Gateway will poll BACnet IP and/or BACnet MS/TP slaves or servers, and retain copies of selected object properties. Upstream BACnet clients may then query the MQ-73 to receive data originating from multiple devices.



MQ-73 Stand-Alone Remote Monitoring

The MQ-73 includes a secure local email client that will directly email you notifications of alarm events. The event rule template has all of the same power and flexibility as the MQTT publish template. The email message template lets you fully customize the message that is sent. The template includes variables which insert real time data from the MQ-73 as the email is sent.

The MQ-73 includes local data logging capability that can be used instead of sending data to the cloud. You select which data points are logged to a local CSV file. This file is then emailed to you periodically. You select logging rate and when files should be sent. You also have the option of logging at a slower rate most of the time, but then log faster when an event of interest is in progress.

Local Object	Header Label/Object Name	Include in CSV file
AI 1	Analog Input 1	<input checked="" type="checkbox"/>
AI 2	Analog Input 2	<input checked="" type="checkbox"/>
AI 3	Analog Input 3	<input checked="" type="checkbox"/>
AI 4		<input type="checkbox"/>
AI 5		<input type="checkbox"/>
AI 6		<input type="checkbox"/>
AI 7		<input type="checkbox"/>
AI 8		<input type="checkbox"/>
AI 9		<input type="checkbox"/>
AI 10		<input type="checkbox"/>
AI 11		<input type="checkbox"/>
AI 12		<input type="checkbox"/>

	A	B	C	D	E
1	Timestamp	Analog Input 1	Analog Input 2	Analog Input 6	Analog Input 7
2	2021-10-25T15:09:29-05:00	6999	5869	-423	8226
3	2021-10-25T15:19:29-05:00	6999	5869	-423	8226
4	2021-10-25T15:29:29-05:00	7003	5888	-360	8274
5	2021-10-25T15:39:29-05:00	7023	5923	-320	8331
6	2021-10-25T15:49:29-05:00	7130	6041	-186	8486
7	2021-10-25T15:59:29-05:00	7140	6116	-97	8560
8	2021-10-25T16:09:29-05:00	7222	6181	-12	8603

The MQ-73 includes a real time scheduler for scheduling daily events or one time events on a given date and time. The scheduler also includes exceptions for holidays.

FEATURES

- MQTT Client supports AWS IoT Core, Mosquitto MQTT, ThingsBoard
- Simple template based setup of MQTT Publish and Subscribe
- Secure local email client for local alarm notifications
- Local data logging for remote monitoring without any cloud
- Real time event scheduler
- BACnet IP to MS/TP Router
- Slave proxy to support MS/TP slave-only devices
- Client/Server gateway for remapping BACnet objects
- Read/Write any standard BACnet objects as a Gateway
 - Up to 1,000 objects, up to 100 mapped to IoT
 - Analog, Binary, Multi-State object types
 - Input, Output, Value objects
- BBMD, COV support
- Commandable BACnet objects implement priority array
- Bidirectional data exchange between BACnet and IoT
- Configure via web pages, HTTP and/or HTTPS
- Flash file system for XML configuration files, SSL certificates
- Online help, Quick Help section at bottom of every web page
- Password protection for web log-on and ftp
- DHCP or static IP address, IPv4 and IPv6 support
- Hardened EIA-485 transceiver for BACnet RTU
- Powered by 10-30VDC or 24VAC 50/60 Hz (0.1A @ 24VDC)
- Panel mount, 70mm H x 131mm W x 38mm D
- Pluggable screw terminal block for power & RTU network
- Operating temperature -20°C to +75°C; Humidity 5% to 90%
- FCC Class A, CE Mark

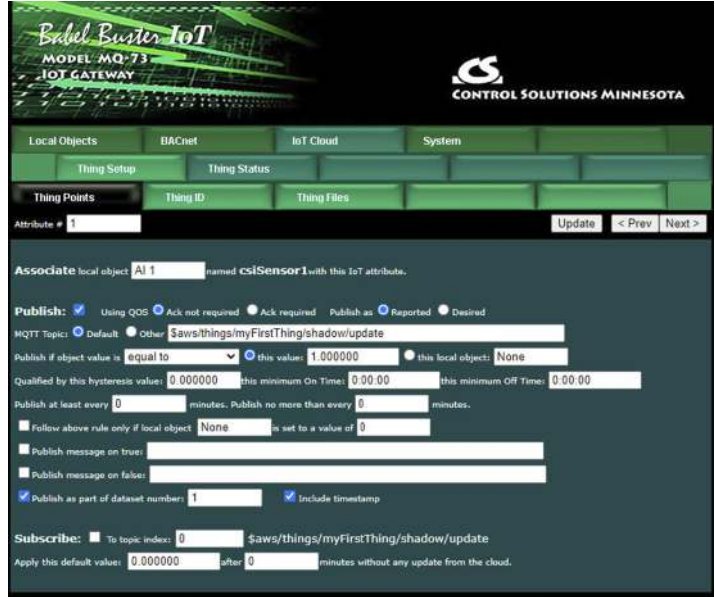

The MQTT publish and subscribe “rules” are created with an easy to use template. A diagnostic page is also provided where you may view the most recently published data, and publish arbitrary JSON formatted data for testing purposes.

Configuration of the gateway is done via the secure web pages served by the internal web server. You simply fill in templates. The entire configuration is saved in the internal Flash file system in XML format. This file may be exported to replicate additional 000 copies of the configured device, or for backup.

Visit our web site for

- Full details
- User Guides & Software Downloads
- Pricing & On-line Ordering

www.csimmn.com



CONTROL SOLUTIONS MINNESOTA
 PO BOX 10789
 ST. PAUL, MN 55110-0789
 VOICE (651) 426-4410 • FAX (651) 426-4418
 TOLL FREE 1-800-872-8613

© 2022 Control Solutions, Inc. Babel Buster® is a registered trademark of Control Solutions, Inc. BACnet® is a registered trademark of American Society of Heating, Refrigerating and Air-Conditioning Engineers, Inc.